

Stock Tool Holders for Keyway and Slotting Inserts (mm)

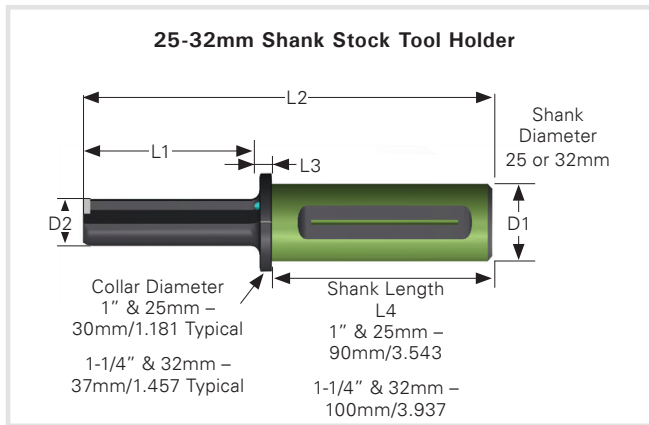

25 & 32mm Shank Stock Tool Holders for Keyway and Slotting Inserts

Description provides: Tool Holder Size — Length Designation Standard or Long.

See Pages 50-51 for Accessories.

Tool Holder Accessories											
EDP - 25mm Shank D1"	EDP - 32mm Shank D1"	Description Tool Holder Size	Minimum Bore Dia. (mm)	Stem Dia. (D2) (mm)	Stem Length (L1) (mm)	Overall Length (L2) (mm)	Centering Plate	Mounting Screw	Driver	Thru Tool Coolant	
99000	99030	2-S	8	6.5	25	124	CP-0	MS-1	T08	Yes	
99001	99031	2-L	8	6.5	35	134	CP-0	MS-1	T08	Yes	
99002	99032	3-S	9	8	30	129	CP-1	MS-1	T08	Yes	
99003	99033	3-L	9	8	40	139	CP-1	MS-1	T08	Yes	
99004	99034	4-S	11.5	10	40	139	CP-1	MS-1	T08	Yes	
99005	99035	4-L	11.5	10	56	155	CP-1	MS-1	T08	Yes	
99006	99036	5-S	13.5	12	46	145	CP-1	MS-1	T08	Yes	
99007	99037	5-L	13.5	12	66	165	CP-1	MS-1	T08	Yes	
99008	99038	6-S	18	16	56	155	CP-2	MS-2	T15	Yes	
99009	99039	6-L	18	16	81	182	CP-2	MS-2	T15	Yes	
99010	99040	8-S	22.5	20	68	162	CP-2	MS-2	T15	Yes	
99011	99041	8-L	22.5	20	100	199	CP-2	MS-2	T15	Yes	
99012	99042	10-S*	28	25	86	185	CP-3	MS-3	T20	No	
99013	99043	10-L	28	25	126	225	CP-3	MS-3	T20	No	
99014	99044	12-S*	33	30	102	203	CP-3	MS-3	T20	No	
99015	99045	12-L	33	30	161	260	CP-3	MS-3	T20	No	
-	99046	14/16-S	40	35	126	231	CP-4	MS-3	T20	No	
-	99047	14/16-L	40	35	180	285	CP-4	MS-3	T20	No	
-	99048	18/25-S*	47	40	140	249	CP-5	MS-4	5mm-Hex	No	
-	99049	18/25-L*	47	40	200	309	CP-5	MS-4	5mm-Hex	No	

*Collar Length 11mm